



**Printers'
National
Environmental
Assistance
Center**

Fact Sheet

PNEAC

www.pneac.org

1-888-US-PNEAC

Litho Printer Reduces Ink Waste With Innovative Sheetfed Ink Pumping System

By Gary A. Jones

Introduction and Background

John Roberts Company, a large commercial printer located in Minneapolis, MN, has installed a new ink pumping system that has reduced ink waste by over 2,000 pounds per year, which has translated into a savings of about \$20,000 per year. The ink pumping system has allowed John Roberts to extend its commitment to managing all of its operations in an environmentally sound manner. The company's published Environmental Policy states that its intention to involve employees, suppliers and customers in applying the principle that to conduct business at the expense of the environment is simply unacceptable. John Roberts has vowed to minimize the company's intrusion on the environment through awareness, understanding, education and action.

In the late 1980's the company was confronted with several environmental issues. At that time, the company had no formal means to address these issues. The company established an Environmental & Safety committee and began to develop and implement procedures for improving air and water discharge quality and reducing waste.

The company purchased and installed a centrifuge recovery system to recover residual solvents from soiled shop towels. This enabled John Roberts Company to recover more than 91% of the solvents used, and to recycle those solvents for reuse in the production operations.

Substitutes were found to replace isopropyl alcohol as a wetting agent in fountain solutions, eliminating the release of more than 200 tons of VOCs annually while improving both indoor and outdoor air quality.

By installing state-of-the-art silver recovery systems and wash water re-circulation systems, John Roberts Company has been able to reduce its wastewater discharges by more than 70 percent. On June 30, 1997, Minnesota's Metropolitan Council Environmental Services notified the John Roberts Company that the facility's discharge of industrial waste to the Metropolitan Disposal System was *insignificant* and that they were no longer required to obtain an industrial discharge permit.

Innovative Ink Pumping System

The printing industry often utilizes petroleum-based products (e.g., inks, solvents, wetting agents) that contain volatile organic compounds that can be released into the air. The John

Roberts Company has committed to carefully manage these raw materials to minimize air emissions through a combination of techniques that include source reduction, best management practices and state-of-the-art emissions controls. In its search for technology to reduce ink waste, during 2000 the John Roberts Company began evaluation of an ink pumping system from Accel Graphic Systems called the Sentinel Ink Management System®. John Roberts purchased a system that year and added another one with the purchase of a new press during 2001.

Ink Management System

The Sentinel Ink Management System® is illustrated in Figure 1. A fully automated canister-based system is fitted to each printing unit's ink fountain. Ink is stored in airtight canisters, which are made from 100% post-consumer recycled paperboard. The canister traverses the ink tray by use of a pneumatic linear actuator. A built in electronic sensor continually monitors the amount of ink in the fountain and automatically adds ink when and where needed. The system maintains a constant minimal amount of ink in the ink fountains at all times, reducing the generation of “waste” ink at the end of a press run. The canisters have a unique plunger design that eliminates skinning of opened containers because the canisters are never actually opened and exposed to air. When empty, the canisters contain less than 2% residual waste ink. The canisters are waste stream compatible, and can be disposed of in public receptacles, because the ink remaining in the canister is in compliance with Minnesota’s solid waste reduction regulations.

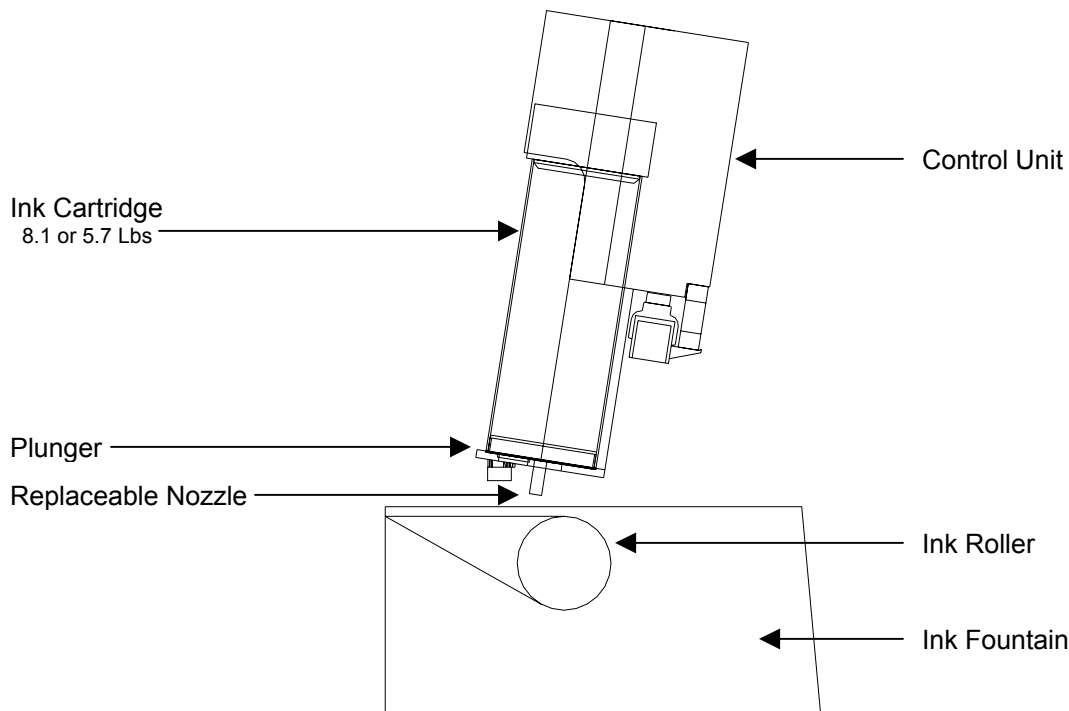

Figure 1: Sentinel Ink Pumping System

Ergonomics

Another added benefit of automated ink dispensing is the elimination of potential injury due to musculoskeletal disorders (MSDs). Ink canister systems offer ergonomic advantages by reducing the repetitive nature of manually filling ink fountains. Some printers may spend in excess of 2 hours in a 12-hour shift putting ink into the ink tray with a knife. The repetitive nature of ink knifing, along with the stress to the wrist, makes this activity subject to scrutiny. Automated ink dispensing eliminates this repetitive motion.

Results and Benefits

The John Roberts company has utilized the Accel Graphic System's Sentinel System since 2000 on their two newest presses, a Heidelberg Speedmaster 40", 2 color units and a Heidelberg CD74 29", 6 color units plus aqua tower with extended delivery. In the first year of operation, the company estimates that these two presses used 674 canisters of spot color inks, eliminating more than 337 pounds of waste ink that otherwise would have been lost to skin removal and residual ink left in traditional 5-pound ink cans. And the company figures that for each spot color run, at job's end there is an additional 1-2 pounds of ink waste eliminated during ink fountain clean-up because the system runs within a minimal one pound of ink in the fountain at any one time. Thus, the ink waste avoided from spot colors totals some 1,237 pounds in the first year of operation. For process colors, the company used more than 1,147 canisters that eliminated more than 917 pounds of waste ink in the first year of operation, which has resulted in a total savings of \$19,749 from eliminated ink waste and \$323 in disposal costs. The payback on the units is estimated to be less than 2 years.

John Roberts has been very pleased with the results they have achieved with their new ink management system. In the near future, the company plans on retrofitting several additional presses, two Heidelberg CD Speedmasters 40", 6 color units plus aqua towers and extended delivery, with the Sentinel System. The system has helped them realize another phase in their continued efforts to create a fair and safe environment that is beneficial to both employees and the community around them.

Additional Information

Besides Accel Graphic Systems, another independent ink dispensing manufacturer is Technotrans. Accel Graphic Systems can be contacted at (972) 484-6808 or www.accel-us.com. Technotrans can be contacted at (909)-734-1309, (770)-499-1008, (847)-259-3330 or www.technotrans.de.

The cost of the system for a 40-inch six-color sheetfed press would be less than \$50,000. Because the dispensing system is pneumatic, there is very little maintenance involved with this equipment. Payback for the system depends upon the ink price paid per pound, the format size, number of color units, ink throughput, hourly rate for the press, hourly rate for press operators, reduction in waste due to color variation, time savings for greater press efficiency, and waste disposal costs.

The John Roberts Company has won several state and federal awards and recognitions for its environmental stewardship. For more information about the environmental stewardship of the John Roberts Company, visit their web site at www.johnroberts.com. Click on "Environmental News".

Specific questions about technology, equipment, vendors can be posted on the PrinTech listserv. To subscribe, simply follow the instructions on the PNEAC web site at www.pneac.org.

For more information or to contact someone from PNEAC please visit www.pneac.org and post your request using "Ask PNEAC".

Author:

Gary A. Jones
Manager, Environmental, Health, and Safety Affairs
Graphic Arts Technical Foundation

Written: September 2004

Note: Reasonable effort has been made to review and verify information in this document. Neither PNEAC and its partners, nor the technical reviewers and their agencies, assume responsibility for completeness and accuracy of the information, or its interpretation. The reader is responsible for making the appropriate decisions with respect to their operation, specific materials employed, work practices, equipment and regulatory obligations. It is imperative to verify current applicable regulatory requirements with state and/or local regulatory agencies.

© 2004 PNEAC